

# SVIII

ELECTRONIC COUNTING SYSTEMS



# SWIFTPACK WORLD LEADER IN ELECTRONIC COUNTERS

Swiftpack was established in 1985 to manufacture electronic tablet counters to meet the stringent demands of the pharmaceutical and healthcare industries.

The basic philosophy was to build versatile counting/filling systems to pack a variety of products accurately at speed, which require few or no change parts to allow maximum productivity. The Swiftpack range of machines also includes unscramblers, cappers and all other ancillary equipment that allow the supply of complete counting lines; the lines integrated by IMA allow customers to get a complete packaging solution and service from a single supplier.

Ongoing development has seen the range evolve to include counters capable of product inspection and offering the even higher levels of GMP, speed, accuracy and versatility that Swiftpack users have come to expect.

With over 3500 installations world-wide, Swiftpack is committed to continued development and to maintaining its position as the world leading manufacturer of electronic tablet counting systems.





SVIII is the new counter developed from the Swiftvision experience that boasts over 300 machines supplied.

Thanks to an updated design the SVIII is able to maintain the same reliability of the Swiftvision machines range whilst adding the following new features to make this counter even more reliable and simpler to operate.

The new features are:

- Flow control through counting rate feedback for a more accurate tablet flow. No maintenance required.
- Single vibrator cover allowing easier and faster cleaning.
- Redesigned count head and pre-count gating facilitating easier count head removal and better access for cleaning and maintenance.
- New power lift mechanism.



# SVIII ELECTRONIC COUNTING SYSTEM



## HOPPER AND VIBRATORY TRAYS

- Product is loaded into hopper
- Rear vibrator tray moves product over sieve plate
- Sieve plate removes dust and particles
- Product moves onto the centre vibrator tray
- Front tray continues to separate and feed product to counthead

## COUNTHEAD

- Product is counted as it passes through the counthead
- On completion of count, the filled container exits, whilst the pre-count gates allow counting to continue until a new empty container is in the filling position
- Clear plastic guarding and the minimal overhang of the machine over the conveyor enables exceptional visibility of the packaging operation.

## OPTIMUM PRODUCT FLOW CONTROL

Count speed and accuracy are optimised through Swiftpack's feed system, where the use of vibratory trays are utilised to feed product from a bulk hopper to the counthead. This motion gently moves tablets down each feed track for presentation to the counthead.

The electronics uses an intelligent "control-loop" in order to control the flow of product from the hopper and feed rate. The operator selects the required recipe where the target count and required speed in bottles per minute has already been entered. The machine calculates the required tablet flow rate and sets this as a target.

As tablets are fed through the counting head, the software measures the throughput of tablets; if this does not meet the required rate then the machine will automatically increase the output of tablets from the rear tray until it is reached. The software will continue to measure the throughput of tablets as the machine continues to run and will increase or decrease the output from the rear tray in order to maintain the required rate.



## BOTTLE EXIT AND BOTTLE REJECTION

- Good bottles proceed while bottles containing errors, such as an overcount or invalid tablets in case of EFS, are rejected.
- The rejection of the bottle is confirmed by a sensor to verify the correct process

## HMI

In production the counting process is easily managed using touch screen controls providing clear information on the current production status and the machine recipe parameters.



# SVIII ELECTRONIC COUNTING SYSTEM



SVIII Single



SVIII Twin

## CONFIGURATIONS

The counter is available in single, twin, duplex configuration or in multiples of them to give speed capabilities from 10 - 160 bottles per minute dependent on count per bottle. In the case of twin and multiple configurations, all machines are operated via a single touch screen, therefore giving optimum control.

## OPTIONAL EQUIPMENT

- Electrostatic field sensors (EFS)
- Additional sets of contact parts for fast change over
- 21 CFR PART 11 compliance
- OPC UA connection
- Special trays for unique products and counting handling
- Dedicated dust extraction units for extremely dusty products

# SWIFTPACK COUNTING TECHNOLOGIES

The counting accuracy depends on many factors such as counter design, product flow control, gating system and, last but not least sensors. Over the years Swiftpack has developed new solutions in order to improve quality and efficiency.

**SENSORS ARE NOT ONLY ABLE TO COUNT PRODUCTS CORRECTLY BUT ALSO TO WORK IN DIFFICULT CONDITIONS.**



## OPTICAL SENSOR

Extremely reliable, accurate and proven technology, the infrared emitter and receiver is able to scan at very high rate (16 scans per millisecond). A detected product that falls between minimum and maximum Dark Time is considered a good product and counted. Sensors can detect and count two tablets falling closely together but not completely overlapped.

## E.F.S. (ELECTROSTATIC FIELD SENSOR)

Suitable for dusty products, E.F.S. is a unique sensor that is able to discriminate between a referenced good product and broken or oversized tablets, empty or half empty capsules. E.F.S. is a dust immune sensor. The system is suitable to handle both capsules and tablets.

The table below indicates the detection capabilities of the optical and E.F.S. sensors for different tablet/capsule damage and scenarios. If they are not detected then they will be counted as a good product, if they are detected then the machine will reject the bottle containing that product.

	Half tablet or capsule	Capped tablet	Tablet chip	Double tablet	Double tablet	Part of tablet	Empty capsule	Half empty capsule
OPTICAL SENSOR	NO	NO	NO	YES (Count as double)	NO	NO	NO	NO
E.F.S. (ELECTROSTATIC FIELD SENSOR)	YES	YES	YES	YES (Count as double)	YES (Count as double)	NO	YES	YES

Tests with active product are needed in order to confirm definitive results.

## CAMERA

Counting machines can be equipped with a Camera Vision System to detect cross contamination (products with different colours).



# CONTACT PARTS REMOVAL FOR CLEANING

## CONTACT PARTS

With a minimum amount of contact parts and easy quick removal, the SVIII allows for a very fast and efficient cleaning procedure. Thanks to quick release captive fasteners the use of tools is eliminated. Complete dismantling for cleaning is achieved in less than 5 minutes.

## COUNTHEAD AND FILLING CHUTE REMOVAL



**HOPPER AND VIBRATOR  
TRAYS REMOVAL**



# SALES AND SERVICES

IMA Safe's goal is to become a partner for its customers. To respond to every requirement with customised solutions and guarantee maximum flexibility and professionalism.

The relationship IMA Safe builds with its customers does not end with a sale. With after-sales service tailored to the customer's specific needs, it lasts for the duration of the machine's lifespan. That's why IMA Safe can count on high levels of customer retention around the world.



## SUPPORT SERVICES

- Telephone online
- On site service
- Remote support assistance
- Production support
- Relocation service
- Spare parts



## PRODUCTION SERVICES

- Mechanical and electrical upgrades
- Technical audit



## MAINTENANCE SERVICES

- Single inspection by technician on site
- Remote experts consultation
- Maintenance optimization strategy
- E-check
- On site practical maintenance training



## TRAINING SERVICES

- Training programs

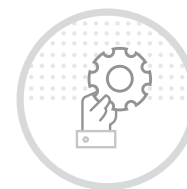

## FORMAT PARTS SERVICES

- Format parts



## IMA REMOTE ASSISTANCE SOLUTIONS

IMA Digital Service Solutions aim to offer remote support and to restore production quickly. Through selected tools, an IMA expert remote is able to promptly support the resolution of technical problems occurred on the machine.

### Quick-kit

Quick-Kit Solutions consists of an action camera installed on headphones. The technician is able to frame what he is directly observing, speaking in real-time with the remote expert and at the same time receiving audio guidelines to carry on the operations.

### Hololens 2

Hololens 2 allows combining different benefits through the use of a new generation viewer. It becomes possible to frame the surrounding environment directly by integrating elements of augmented reality (drawings, diagrams, documentation) shared by the IMA Expert remote.

# TECHNICAL DATA

## SWIFTVISION (SINGLE)

Production (subject to trial confirmation)	Up to 60 bpm or 6,000 tablets per min depending upon product and container size and shape
Container diameter range	25mm - 100mm
Container height range	40mm - 200mm
Hopper capacity	27 litres
Single conveyor	Height 915mm + – 50mm length 2.5mtr
Power	220/240 volts 1ph neutral + earth 50 Hz (2 Kw) 110 volts 1ph neutral + earth 60 Hz (2 Kw)
Compressed air	110 ltr/min @ 6 bar
Weight	600 Kg
Contact parts	Generally 316L St/St + pharmaceutically approved materials

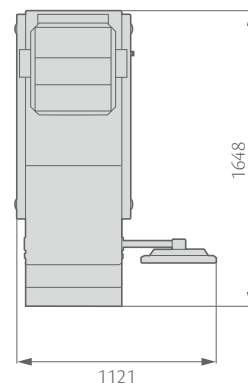
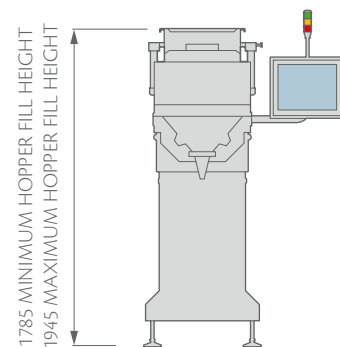

## SWIFTVISION (TWIN)

Production (subject to trial confirmation)	Up to 120 bpm or 12,000 tablets per min depending upon product and container size and shape
Container diameter range	25mm - 100mm
Container height range	40mm - 200mm
Hopper capacity	2 x 27 litres
Single conveyor	Height 915mm + – 50mm length 2.5mtr
Power	220/240 volts 1ph neutral + earth 50 Hz (2 Kw) 110 volts 1ph neutral + earth 60 Hz (2 Kw)
Compressed air	220 ltr/min @ 6 bar
Weight	1115 Kg
Contact parts	Generally 316L St/St + pharmaceutically approved materials

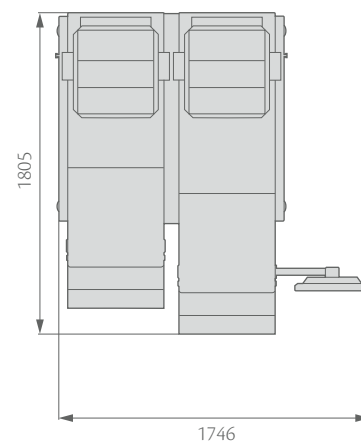
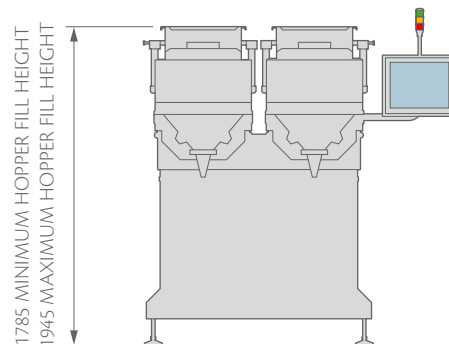

The dimensions are indicative and can vary depending on the optional groups chosen and machine layout.

ima.it

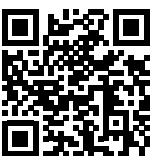

**IMA SWIFTPACK Ltd**

3 Arden Road, Arden Forest Industrial Estate, Alcester, Warwickshire B49 6HN, United Kingdom.  
Tel: +44 (0)1789 400880 • Fax: +44 (0)1789 400780

