

C1060/C1075 AUTOMATIC TUBEFILLER

FOR PHARMACEUTICAL, COSMETIC AND FOODSTUFF PRODUCTS



C1060/C1075 AUTOMATIC TUBEFILLER

A COURSE OF
CONTINUOUS GROWTH



It was in 1970 that COMADIS launched the first of a successful tubefillers series. Since then, more than 3.000 machines have been supplied all over the world, as a result of continuous technical commitment coupled to a rewarding operating mentality - always oriented to customer feedback and satisfaction.

Since the beginning, COMADIS tube filling machines have been marked by simplicity in change-over sequences, quick dismounting of contact parts and intuitive operator interface: we are proud to offer continuous improvements and advances in technology to our machines in the range of 1.500 to 15.000 tubes per hour.

A course of continuous growth, that in time brought COMADIS to gain an enviable experience in the field, testified by the multitude of both large and small customers. A valuable reputation to be proud of, to bring as a heritage in any new project we approach.

Born to repeat the success of the extraordinary C960/C970 series, the new C1060/C1075 family comes to the market with experience enough to maintain its supremacy in medium speed tubefilling segment.

The approach to development of this model was based on throughout fine-tuning, introducing substantial upgrades while retaining its innate design flexibility to deal with several applications.

Thus the new C1060/C1075 series still remains the "quintessence" of reliability, ergonomoy and ease of use: this recipe for success remains unvaried, as well as the concept of "top class performance in compact size".



AUTOMATIC TUBEFILLER
FOR PHARMACEUTICAL,
COSMETIC AND
FOODSTUFF PRODUCTS

C1060/C1075 AUTOMATIC TUBEFILLER

THE OUTPUT

C1060

- Up to 60 metal, polythene, laminate and polyfoil tubes/minute.

C1075

- Up to 75 metal, polythene, laminate and polyfoil tubes/minute.

DOSING SYSTEM

C1060/C1075

- diving nozzle with positive shut-off valve and nozzle cleaning by air blow; mechanically driven dosing pump, by close cam.

DESCRIPTION

- Reinforced base frame, safety guards frame and electrical cabinet made of stainless steel.
- 10-position turntable.
- Direct drive of main shaft without chains, by directly connected brake gearmotor
- Centralized lubrication system.
- Safety devices for tube feeding, filling, closing and ejection, as well as for machine overloads.
- Simplified and easy change of size parts, without tools.
- Easy access from all the four machine sides for maintenance and cleaning.
- Enlarged electrical cabinet integrated within machine footprint, hinged and completely insulated from mechanical drive.
- Machine functions control and management by next-gen PLC
- Machine speed adjustment from operator panel (HMI) by means of inverter.

- Programmable "touch screen" colour panel (HMI), suitable to perform the digital adjustment of following working parameters:
 - machine speed
 - machine phases
 - with capability to memorize set values according to tube sizes (by recipes).

Also showing:

- machine alarms
- troubleshooting of faults
- timers and counters.
- Batch data collection – by pen drive – via USB port, allowing the operator to carry out a daily collection of production data and register of alarms occurred.
- Tube loading by :
 - inclined plane
 - easy-to-adjust cassette feeder
 - independent ergonomic feeder
 - All they are positioned outside machine working area as per GMP norms.
- Conical tubes feeding.
- Tube cleaning by adjustable airflow and dust aspiration device by vacuum, located in vertical position (on dedicated station)
- Automatic print registration by step-motor, available in both above and bottom drive executions.
- Magnetic (non-contact) switches to control the safety doors
- Bar-code reading device (pharmacode).
- Nitrogen flushing before and after filling.
- Easy-to-disassemble product dosing pump.



FOLDS

Closing folds
for metal tubes

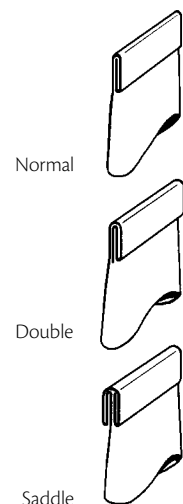

- All parts in contact with product made in stainless steel AISI 316, 280 grains polished.
- Dosing accuracy $\pm 0,5\%$.
- Adjustment of filling volume by external handwheel provided with digital counter, or automatic from operator panel (HMI) with possibility to memorize the dosing values by recipe
- Heated hopper with forced water circulation in closed circuit.
- Stainless steel product scraper stirrer with drive from inside machine base.
- Adjustment of air blow for nozzle cleaning from control panel
- Additional dosing unit for sodium bisulphite anti-oxidant drop dispensing.
- Hopper for product feeding by pressure.
- Metal tube closing unit for normal, double and saddle fold.
- Thermosealing of different polythene (PE), laminate (ABL-PBL) and polyfoil tubes with following technologies:
 - hot air, hot jaws, high frequency
- Possibility to obtain customized «designer seals».
- Quick interchangeability of closing / sealing heads for aluminium, polythene and laminate tubes.
- IQ-OQ - Validation documentation.

SPECIAL EXECUTIONS

- Handling of tubes with different body shapes such as unidoses, canulas and vet syringes.
- Configuration suitable for sterile areas with laminar flow unit.
- Laser engraving unit, with possible vision system to control the correct marking.
- Explosion-proof execution according to Atex standards.



SEALS

Some seal shapes for polythene or laminate tubes obtainable by hot jaws or hot air technologies

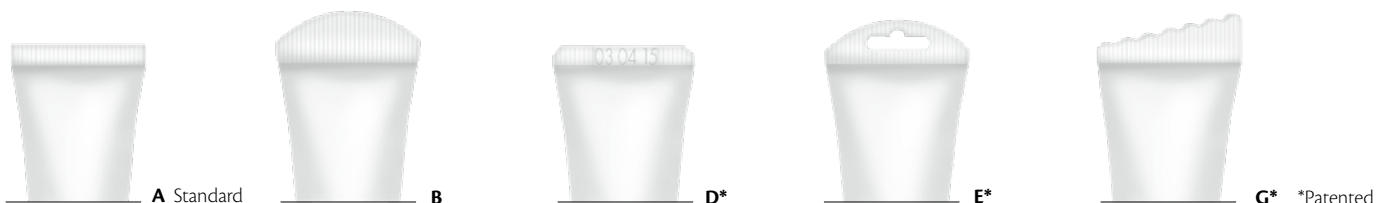

TECHNICAL DATA

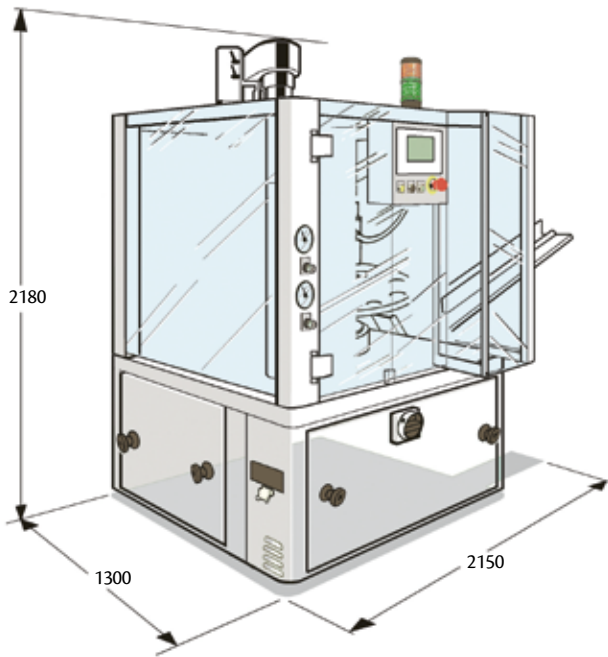

With inclined plane

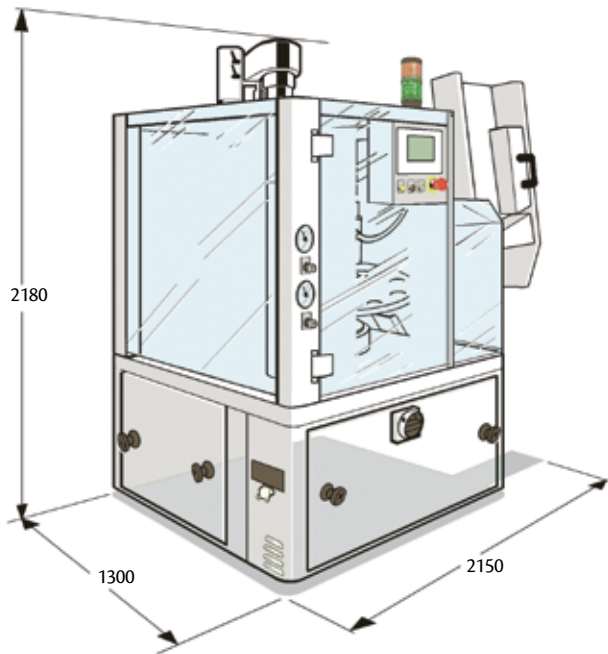

With automatic tube feeder

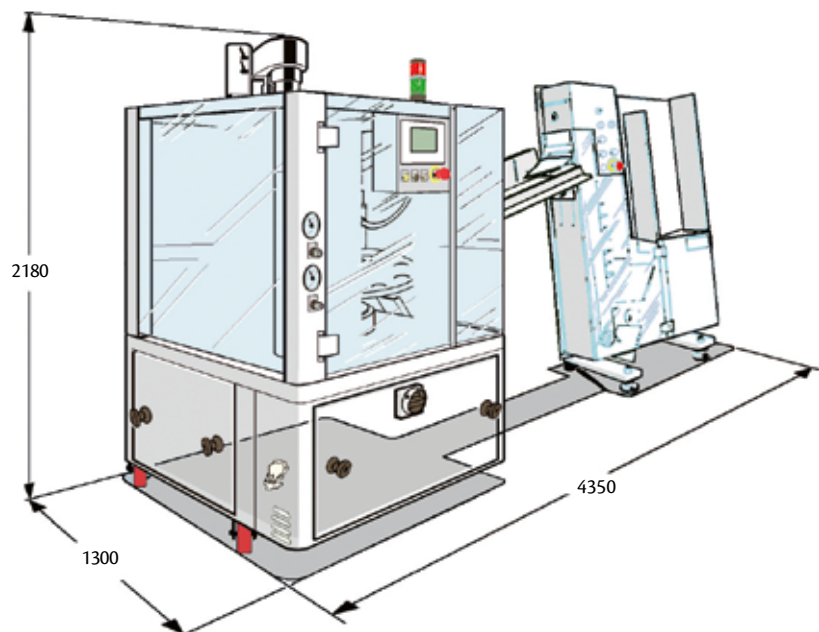

With independent ergonomic tube feeder

Maximum speed	60/min. (C1060) 75/min. (C1075)
Filling volume (ml)	2-250 (on request up to 500)
Tube diameter (mm)	10-50 (on request up to 60)
Tube length (mm)	60-280
Power consumption	
Main motor (kW)	1.2
Scraper stirrer (kW)	0.3
Heated hopper (kW)	1.5
Print registration (kW)	0.1
Vacuum cleaning (kW)	1.1
Hot Jaws (kW)	1.8
Hot Air (kW)	3.0
High Frequency (kW)	2.5
Compressed Air max.	6 bar - 100 ÷ 250 NL/min
Cooling water (lt/min)	5
Noise level (dB A)	below 79
Export packing	
Approx. dimensions (cm)	270 x 170 x h 220
Approx. weight (kg)	1.300

TECHNICAL ASSISTANCE

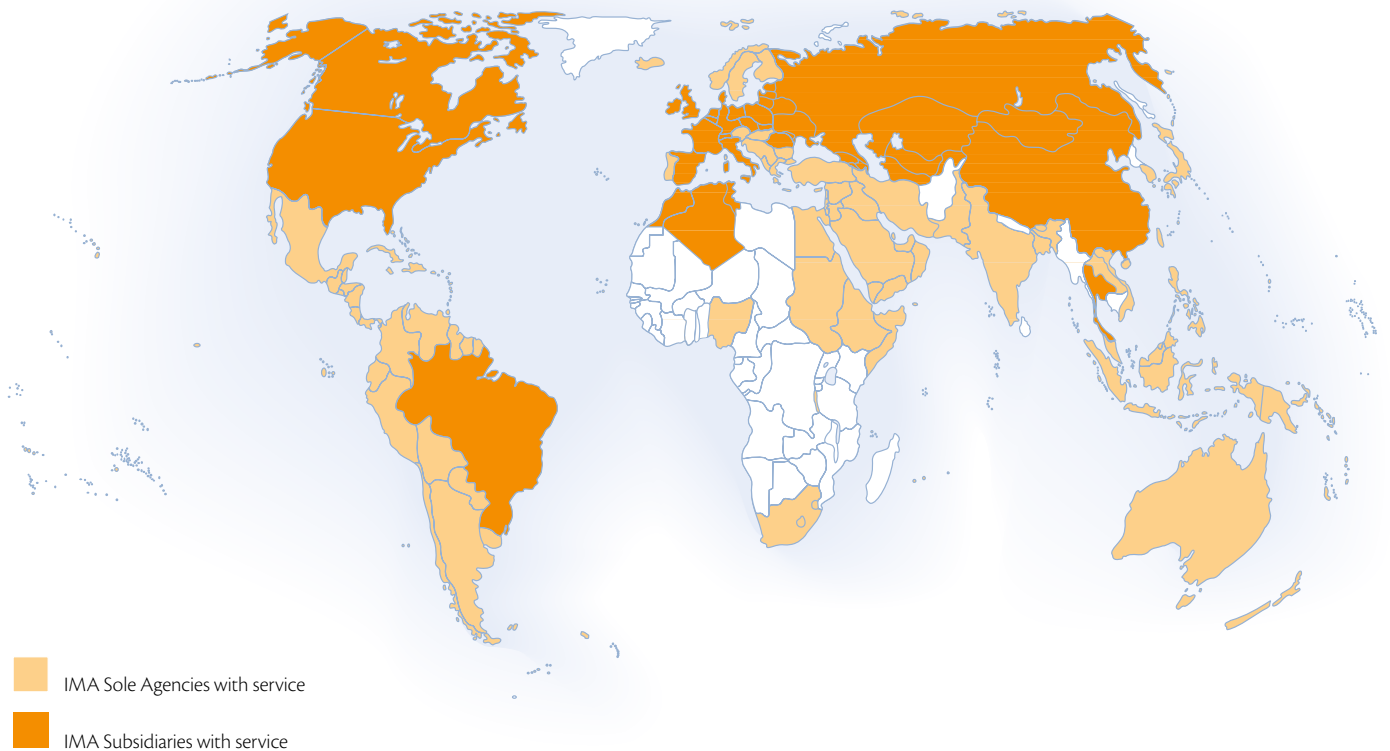

IMA UNDERSTANDS THE NEED FOR EXCELLENT SERVICE AROUND THE WORLD

- PRESENT IN OVER 70 COUNTRIES
- 10 BRANCHES PROVIDING SALES AND SERVICE
- MORE THAN 50 REPRESENTING AGENCIES
- 90 TECHNICIANS FROM ITALY TO SUPPLY WORLDWIDE SERVICE
- 50 TECHNICIANS FROM LOCAL SUBSIDIARIES AND AGENCIES
- 11 AFTER SALES SUPERVISORS

IMA SAFE provides prompt and effective technical assistance which covers the entire life cycle of its equipment. This assistance is provided by a dedicated team of experts who are able to meet our client's needs on a day to day basis. A customer oriented after sales service staff is what distinguishes IMA from the rest of the world.

ORIGINAL SPARE PARTS ARE VITAL TO ASSURE THE CORRECT AND PROPER FUNCTIONALITY OF IMA SAFE EQUIPMENT. SPARE PARTS ARE ALWAYS AVAILABLE AND CAN ARRIVE AT THE CLIENT'S SITE WITHIN 24/36 HOURS.

DOCUMENTATION AND VALIDATION

In the pharmaceutical industry, the validation of a production process implies the provision of documented evidence to demonstrate that the process is capable of producing a consistent product which conforms to predetermined specifications and quality criteria.

Upon request IMA Safe CO.MA.DI.S. will provide customers with a comprehensive package of documentation to support on-site validation procedures in the most simple and fast way. Different packages are available according to individual requirements.

ima.it



CO.MA.DI.S. S.p.A.

Via Piemonte 32/34/3620030 Senago (Milano) - Italy
Tel +39 02 99010284 - Fax +39 02 99010803
sales@comadis.ima.it

